



CPDC2X1

2X1 GPS Combiner

Technical Product Data



Features

- **Excellent Flatness**
- **Extremely Flat Group Delay**
Less than 1ns variation
- **Low Insertion Loss**
- **Passes all GNSS Frequencies (Entire L-band)**
- **Provides Antenna redundancy**
Allows receivers to function with a failed antenna
- **Phase Matched Outputs**
- **Special Configurations Available By Request**

Description

The CPDC2X1 GPS Combiner (GNSS Combiner) is a two input, one output device. The frequency response covers the entire L-band (all GNSS Frequencies) with excellent flatness. In the standard configuration, DC is passed from a connected GPS device through the combiner to both inputs (antenna ports). The connected GPS device or receiver will continue to maintain a GPS lock in the event of an antenna failure. Contact GPS Networking Technical Support for any questions regarding standard configurations or special configurations at salestech@gpsnetworking.com or 1-800-463-3063.

Electrical Specifications, T_A = 25⁰C

Parameter	Conditions	Min	Typ	Max	Units
Freq. Range	Antenna/Input – Any Output, Unused Outputs - 50Ω	1.1		1.7	GHz
Input/Output Impedance	Antenna/input to output		50		Ω
Input SWR	All ports - 50Ω			2.0:1	-
Output SWR	All ports - 50Ω			1.5:1	-
Insertion Loss	Antenna – Any Output, Unused Outputs - 50Ω	-4.0	-5.0	-6.0	dB
Gain Flatness	Either Input/Antenna port – Output,			1.0	dB
Amplitude Balance	Either Input/Antenna port – Output,			1.0	dB
Phase Balance	Either Input/Antenna port – Output,			1.0	deg
Isolation	Input Ports: Output - 50Ω	20			dB
Group delay Flatness	Antenna 1 – Output, Antenna 2 - Output			1	ns

External Power Options (Networked Option)

Network Power Supply		
Source Voltage Options	VOLTAGE INPUT	
	110VAC	Transformer (Wall Mount)
	220 VAC (2 prong Euro)	Transformer (Wall Mount)
	240 VAC (3 prong UK style)	Transformer (Wall Mount)
	Customer Supplied DC (9-32 VDC)	2-pin Military DC Connector
Output Voltage Options ⁽¹⁾	DC VOLTAGE OUT	
	MAX CURRENT OUT FOR CORRESPONDING Vout	
	3.3V	110mA
	5V	125mA
	9V	140mA
	12V	180mA
	15V	220mA
Custom	TDB	
Standard DC Configuration without External Power Option		
	All ports pass DC	
Standard DC Configuration with any External Power Option (AC/DC or Military DC)		
	Output port DC Blocked	
	User Selected Output DC Voltage	
RF Connector Options		
Connector Options	CONNECTOR STYLE	
	CHARGE	
	Type N-female	NC
	Type SMA-female	NC
	Type TNC-female	NC
Type BNC-female	NC	

(1) With Networked Option, any RF port (input or output) can be selected Pass DC or Block DC.

(Contact GPS Networking Technical Support at 719-595-9880 or salestech@gpsnetworking.com for any questions regarding non-standard configurations and corresponding part numbers)

Part Number Configuration

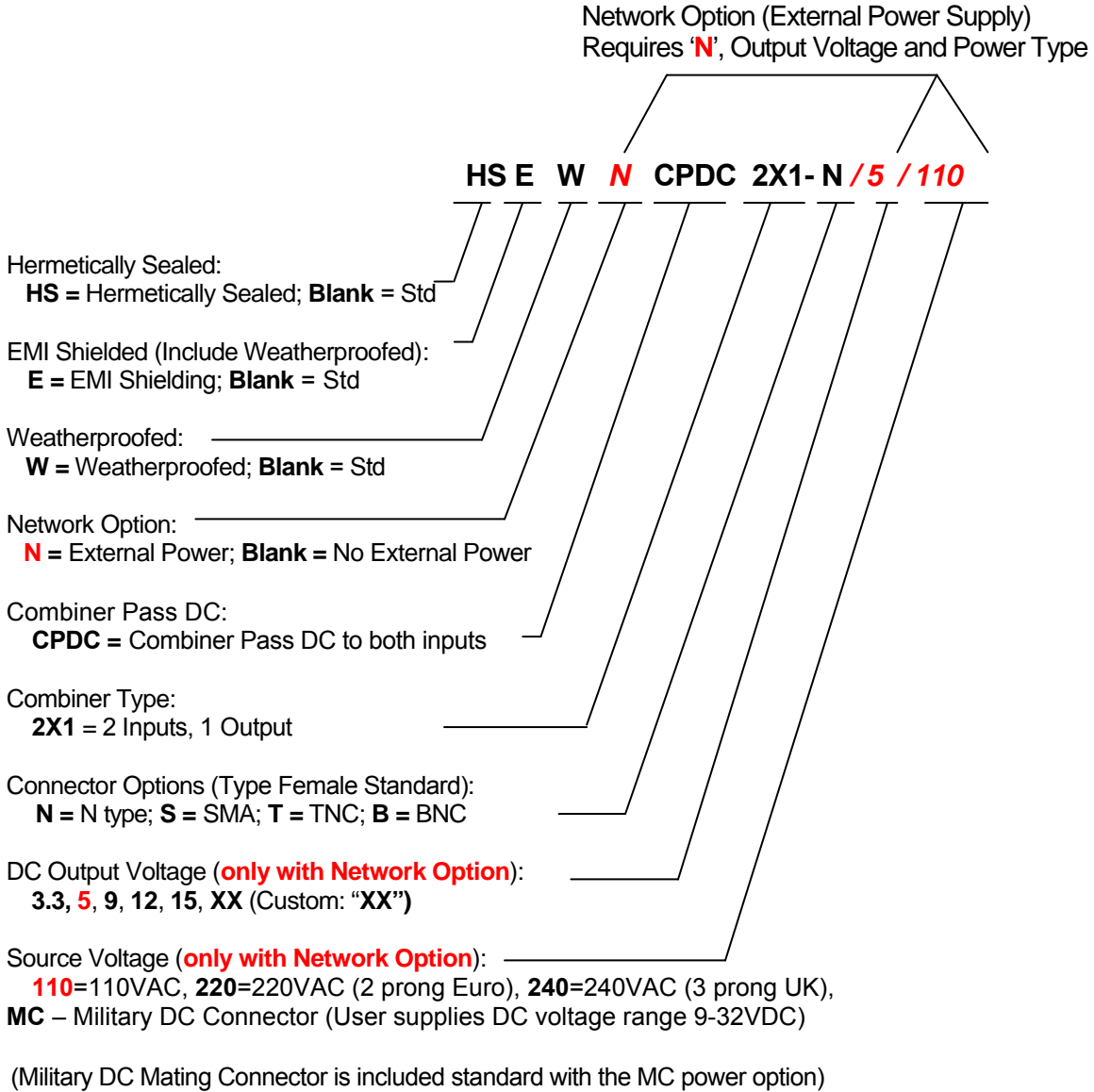

(Contact GPS Networking Technical Support at 719-595-9880 or salestech@gpsnetworking.com for any questions regarding non-standard configurations and corresponding part numbers)

Performance

Typical Frequency Response: Input1/Input 2 To Output, (Type N connectors)

Input SWR: Input1/Input2 to Output - 50Ω (Typical Type N connectors):

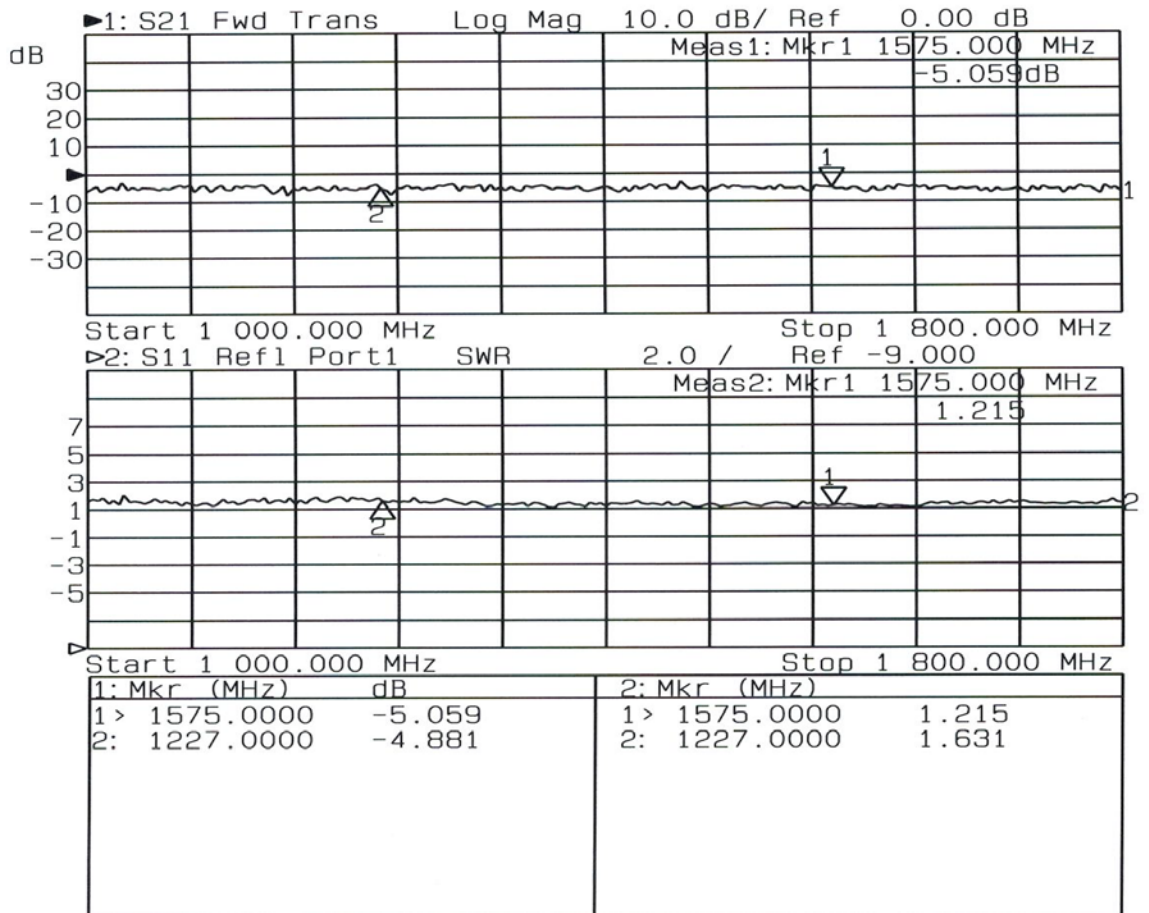

Mechanical

Dimensions: Height: 1.3"
 Length (not including connectors) Body: 2.5"
 Base Plate: 3.25"
 Width (not including connectors): 2.5"

Weight: 11 oz. (316 grams)

Operating Temp. Range: -40° to + 75°C

Finish Housing and Base Plate: ELECTROLESS NICKEL PLATED
 MIL-C-26074C CLASS 1, .0001-.0003 MAX
 Finish Lid: ANODIZE, TYPE II, CLASS 2, BLACK, per MIL-A-8625

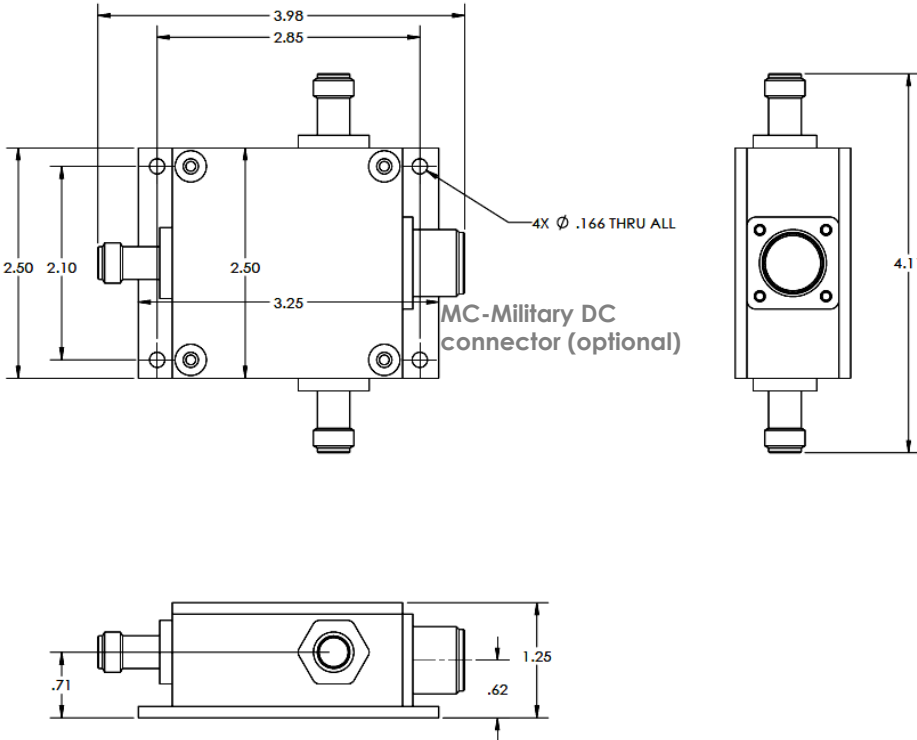

REVISIONS				
ZONE	REV.	DESCRIPTION	REV. BY	DATE
-	A	INITIAL RELEASE	-	--

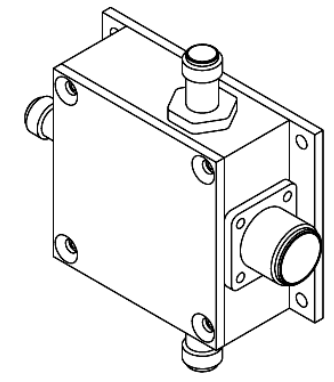

GPS NETWORKING		Assy, 1x2		Do Not Scale Dwg. Remove All Bums And Sharp Edges to J200 Prod Max
Drawn By:	BPC	Date:	06/22/15	Checked By:
Checked By:		Date:		Rev. No.:
Title:		Quantity / Unit Qty:		Part No.:
Part Origin Production:		Material:		See Note
Dwg Number:		Size:		Sheet:
		Assy, 1x2		1 OF 1
				Scale:
				Notes:
				3.0 ± .003
				.001 ± .0015
				.001 ± .0015
				Angle 1.1°
				Surface Finish
				Unless Noted
				Per Drawing
				Unless Noted